

CERN LHC TECHNICAL INFRASTRUCTURE MONITORING (TIM)

U. Epting, P. Ninin, R. Martini, P. Sollander, R. Bartolome, B. Vercoutter, C. Morodo

Abstract

The CERN Large Hadron Collider (LHC) will start to deliver particles to its experiments in the year 2005. However, all the primary services such as electricity, cooling, ventilation, safety systems and others such as vacuum and cryogenics will be commissioned gradually between 2001 and 2005. This technical infrastructure will be controlled using industrial control systems, which have either already been purchased from specialized companies or are currently being put together for tender. This paper discusses the overall architecture and interfaces that will be used by the CERN Technical Control Room (TCR) to monitor the technical services at CERN and those of the LHC and its experiments. The issue of coherently integrating existing and future control systems over a period of five years with constantly evolving technology is addressed. The paper also summarizes the functionality of all the tools needed by the control room such as alarm reporting, data logging systems, man machine interfaces and the console manager. Particular attention is paid to networking aspects, so that reliable and timely transmission of data can be assured. A pyramidal layered component architecture is compared with a complete SCADA solution.

1 INTRODUCTION

The Technical Infrastructure Monitoring (TIM) project was launched to identify the monitoring needs of technical data for the LHC era. Different working groups, such as the LHC Data Exchange WG and the LHC Communication Infrastructure WG, have already been formed by the LHC project management. The TIM project will mainly coordinate the different requirements in order to achieve the desired results at start-up time of the different equipment groups. A project team has been formed for the coordination of the large variety of actions. Separate meetings with the experts from different equipment groups are scheduled to define the technical requirements and the final timetable for implementation of the different services.

2 SERVICES

CERN's technical infrastructure contains several basic services that are necessary to run the laboratory, such as electricity, cooling, ventilation and safety systems. These form the infrastructural base for the experiments. These services will be implemented long before the start-up of the LHC and have to be monitored immediately after their installation. The first installation of ventilation equipment is already scheduled for mid 2000. More systems will follow in short steps. Other services such as vacuum and cryogenics have to be monitored at a later stage of the project. Nevertheless the first test beam in the LHC is foreseen in mid 2003, i.e. all equipment has to be in place and the monitoring has to run in a stable mode. Thus the monitoring technology has to be chosen at an early stage to achieve a homogenous control system and to avoid changes of existing systems in the future. Technical data of the LHC experiments have not to be monitored before 2003, nevertheless an estimation of the planned signals and alarms are needed now to design the control system in order to be ready for the future needs.

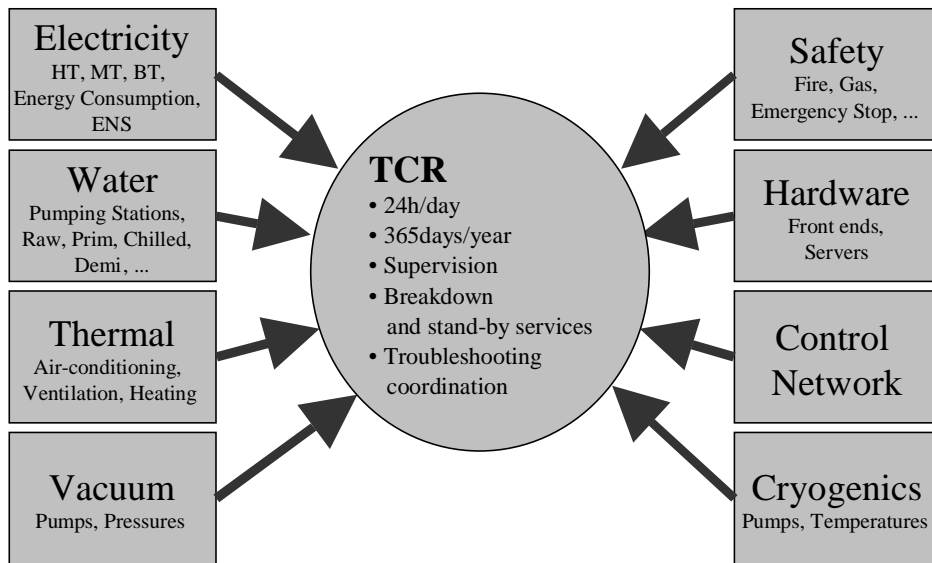

Figure 1: Services.

3 FUNCTIONALITY

The role of TCR is to monitor all CERN technical services. This requires basic functionality such as:

- A console manager, which has the complete functionality for the correct equipment monitoring on one screen. The functionality has to be very ergonomic in order to avoid false actions in case of stress situations.
- Alarm reporting displays, which should have the same look and messages CERN wide. Each alarm message has to be followed by a well defined action. Help texts give detailed information and have always to be kept up to date.

- Synoptic mimic displays, designed for the operators in order to achieve more detailed information of equipment. Only a well balanced amount of information should be displayed, a detailed view for the experts has to be made available upon request. The same look and feel for all applications will be assured by the use of a single tool, which is actually evaluated by the Technical Supervision Interface (TSI) project [1].
- A data logging system that logs selected information for later use or examinations. This system has to be connected to a network database in order to create relations between any other system data or experiment data. The Event Logging System (ELS) project [2] has the first application up and running to ensure this functionality.

The large variety of different installations makes it necessary to define clear Human Computer Interface (HCI) conventions and clear instructions on how to react in case of alarms in order to achieve effective monitoring. This can only be ensured by checking all signals and alarms already at their definition time with an Alarm Integration Procedure (AIP) [3].

Also functions that are not visible have to be provided, like the Alarm Notification System (ANS) [4] that distributes alarm messages directly to the GSM phones of the piquet services.

4 ARCHITECTURE AND INTERFACES

4.1 Overall architecture

The control system has to be able to include a variety of different specific systems and thus is divided in functional components. The equipment systems will interface depending on their functionality and ability to communicate with the control system. Today, the "heart" of the control system is the Technical Data Server (TDS) [5], which has the role of collecting, computing and distributing the data. It is based on the middleware SmartSockets® from Talarian® [6], which works with a publish/subscribe mechanism. The transmission media is an Ethernet/TCP-IP message oriented system. The messages are based on a tag based architecture. Each tag contains information about the device, the physical place and the type of information that is transferred in the message. This makes it possible to migrate easily from a purely tag based system to a device oriented system if necessary.

To keep the system configuration up to date with the reality, all data and system characteristics are stored in a single Technical Reference Database (TDSRefDB)[7]. All necessary configuration files and other dynamic system parameters can be created at any time.

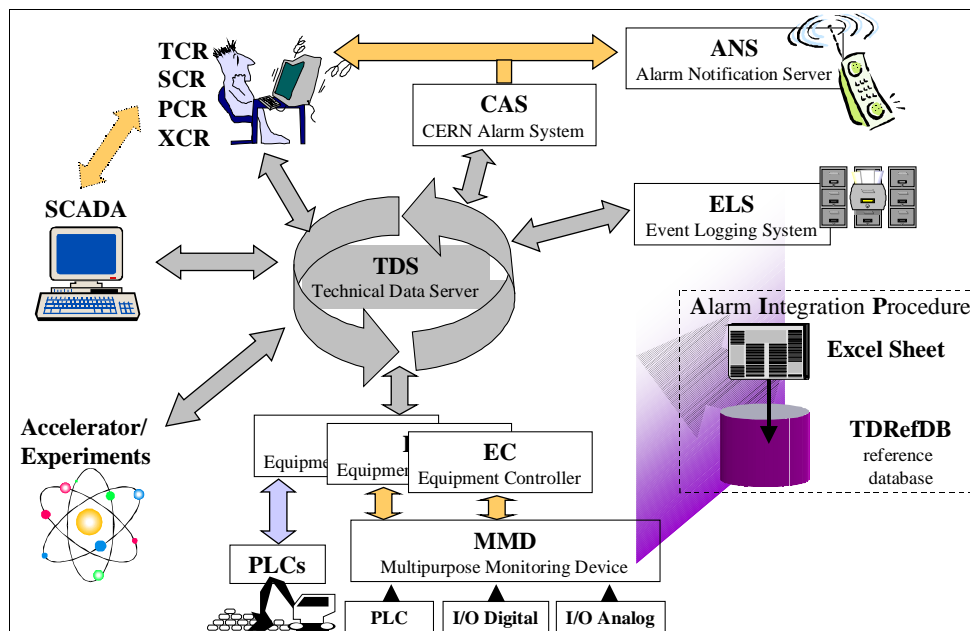

Figure 2: Overall architecture.

4.2 Interfaces

The interfaces are split into two types: incoming signals that have to be monitored and information that has to be distributed to interested groups outside the TCR. Incoming signals are treated via a layered architecture that allows the integration of signals with a variety of different protocols. Outgoing data will be distributed via a CERN wide defined protocol (CERN Data Interchange Bus [8]), presumably on an object oriented architecture using CORBA [9] or a similar product (see Fig. 3).

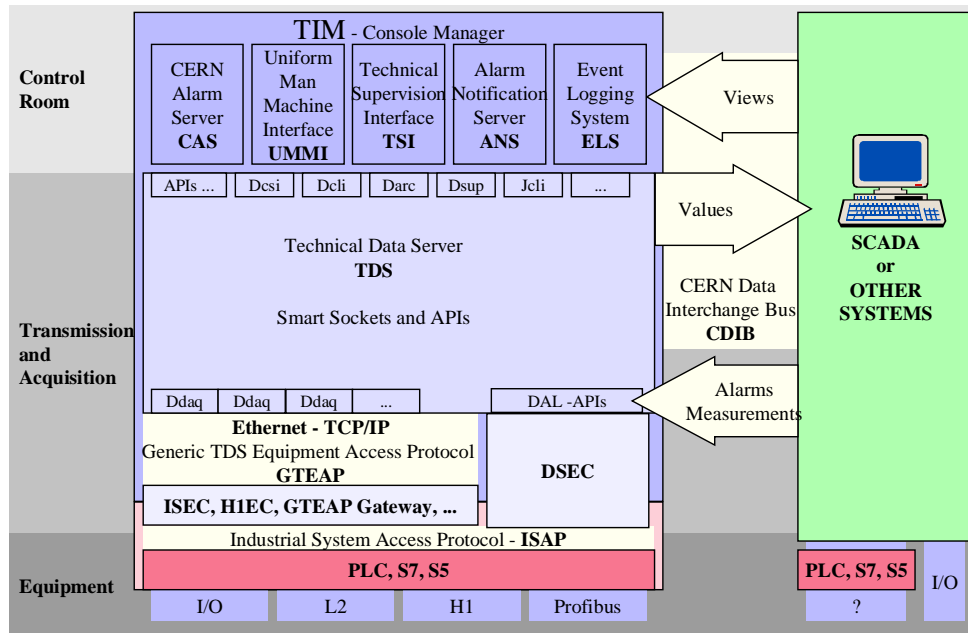

Figure 3: Interfaces.

4.3 Network aspects

As the systems which have to be monitored are distributed over a large area, special attention has to be paid to the network availability. Precautions have to be taken to ensure the full network functionality even during shutdown periods of parts of the control system. Equipment monitoring is necessary without interruption, which means that the main systems have to be redundant and all critical elements must be connected to safe power supplies.

5 SCADA VS. COMPONENT WARE

The actual control system is using a component ware architecture, partly homemade and from a variety of different product vendors. As a lot of the software was written by people who do not work at CERN anymore, it is difficult to maintain the different versions. A full SCADA solution would avoid this problem, as it is maintained by the product vendor. However, this solution does not have the same flexibility, especially for integrating non-industrial products. Compromises have to be made in the functionality and often not all the functionality provided by a SCADA system is used by the applications. The integration of the CERN services into the control system has to be done over a time period of more than five years and the system has to be operational at least another ten years afterwards, thus the chosen products have to provide backward compatibility at each upgrade over the full project lifecycle.

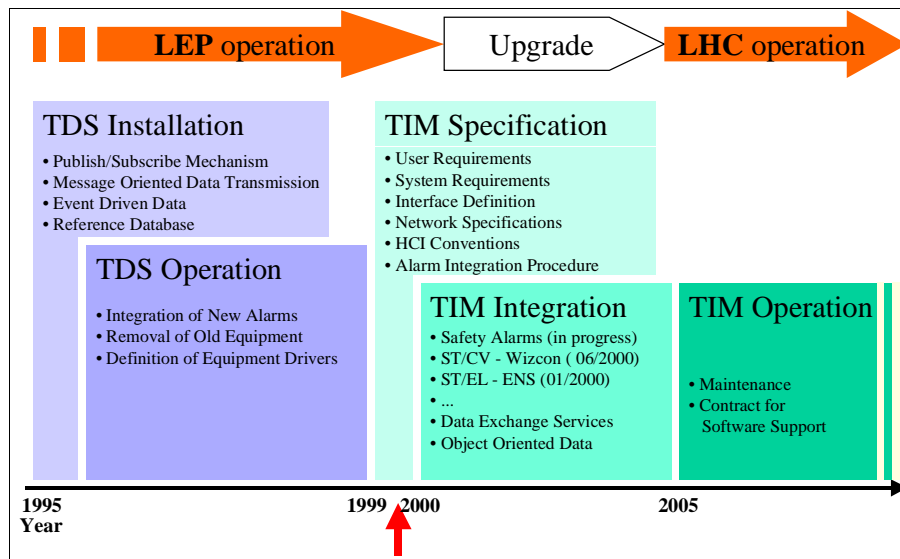

Figure 4: Timetable and future.

6 CONCLUSION

Even if the LHC control system is not yet defined, it will be sure that different equipment groups at CERN will use different products. Thus the coexistence of SCADA systems and component ware will be the reality. The control system architecture has to provide very flexible but well defined interfaces to be able to integrate future equipment components that are not defined yet. Maintenance and configuration tasks will lead very probably to device oriented architectures. Alarms and data signals will be available CERN wide. Logged data from all systems have to be analysed in relation to each other. The challenge of the TIM project is the integration of all these requirements into one coherent and easily maintainable control system over the LHC installation period. The use of industrial standards and the outsourcing of software development and system installation will help to achieve these goals.

REFERENCES

- [1] P. Sollander et al., The Technical Supervision Interface: A Java based synoptic view environment, ICALEPCS'99, Trieste, October 1999.
- [2] M. Zurek, Event Logging System, July 1999.
- [3] M. Batz, Alarm Integration Procedure, May 1999.
- [4] B. Vercoutter, Alarm Notification System, 1997.
- [5] P. Ninin et al., Technical Data Server: a large scale supervision system, ICALEPCS'97 - BEIJING -CHINA.
- [6] Talarian, <http://www.talarian.com/>.
- [7] R. Martini et al., The Technical Information Database for systems monitored by the TCR, 1998.
- [8] LDIWG, Presentation from 17/9/99.
- [9] CORBA, <http://www.corba.org/>.

TIM homepage: <http://nicewww.cern.ch/~stmoin/projects/TIM/tim.html>